

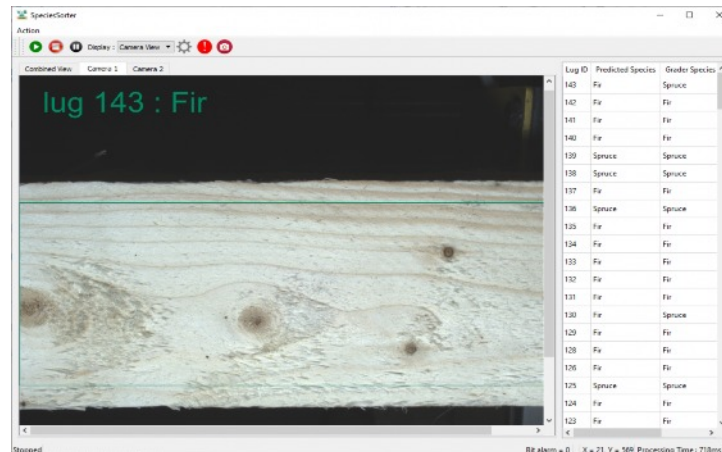

# SPECIES SORTER

VAB introduces its new Species Separator system based on artificial intelligence. After 2 years of research and development, VAB is proud to present its new system that has demonstrated its ability and accuracy to identify and sort wood species in sawmills. Supported by its unique vision and light system, it uses algorithms and statistical models to perform a specific task without using explicit instructions, relying instead on an iteration technique.



## SYSTEM ADVANTAGES

- No chemical products are used in this process. The safety of your staff and the cost of consumables are thus completely eliminated
- No specialized skills or knowledge in the identification of wood species is required to operate the system
- 96% sorting accuracy,
- Saves in drying time
- Increases drying quality and reduces over drying
- Reliable system, low maintenance
- Easy to install and compact
- Minimizes drying defects such as bends, checks and dimensional variations
- Ability to separate SPF species

# SPECIES SORTER

**NO CHEMICAL PRODUCTS USED**  
**NO MORE MANUAL SORTING**  
**96% SORTING ACCURACY**

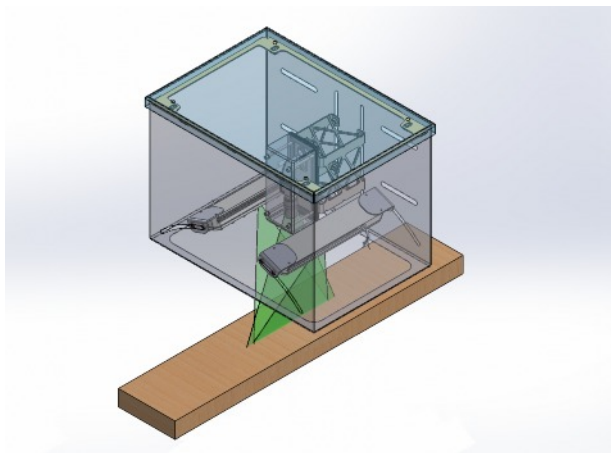

## TECHNICAL SPECIFICATIONS

- Easy integration to the mills PLC
- Simple User Interface
- Complete alarms interface
- Diagnose menu
- Dimensions of 1 x 3 to 4 x 10
- Up To 250 boards per minute



**VAB**

UNE COMPAGNIE DE TIMBER AUTOMATION  
A TIMBER AUTOMATION COMPANY

[www.vab-solutions.com](http://www.vab-solutions.com)

4695, rue de la Pascaline, Lévis (Québec) Canada G6W0L9  
Bureau/Office 866-834-0606 | Téléc./Fax 418-834-0645